

Canister Type Digital Load Cell

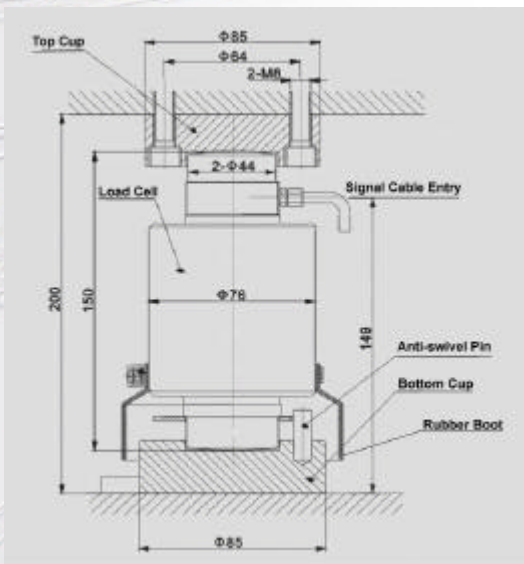

Griffith Elder and Company Ltd
1 Oaklands Park
Bury St Edmunds
Suffolk
IP33 2RW
United Kingdom

Telephone: +44 1284 763616
Fax: +44 1284 700822
Email: sales@griffith-elder.com
Internet: www.griffith-elder.com

Material	Carbon Alloy Steel
Model: CT-15T-CD	Capacity 15,000 kg
Model: CT-20T-CD	Capacity 20,000 kg
Model: CT-30T-CD	Capacity 30,000 kg
Model: CT-50T-CD	Capacity 50,000 kg

Temperature Range	-40 to +70°C
Safe Overload	150%
Maximum Overload	200%
Cable	Connector IP68
Ingress Protection	Sealed to IP68
Excitation	

Recommended	10V to 12V dc
Maximum	15V dc
Minimum	7.5V dc

Output at rated load Weightel™ Protocol RS485