

## Ton-Tel Multi-Deck Weighbridge

*Rugged construction, Accurate weights*



Weightel™  
digital load cells  
from 6 tonnes to 30 tonnes capacity  
OIML Approved



### Plug-And-Weigh™ Proven reliability

### Weightel™ digital load cells for maximum accuracy

### Choice of indicators and software to suit the application

The Ton-Tel is a fast and accurate weighing system which will weigh any type of vehicle regardless of its length or the number of axles. A vehicle drives onto the platforms and a green traffic light shows to tell the driver to move forwards slowly. When in position so that each group of axles is on a separate platform a red traffic light shows and the vehicle must stop. The light turns green to show when to move off the weighbridge. Weighing of each group of axles is automatic and the driver does not need to get out of the cab while the vehicle is being weighed.

The heavy duty construction of the multi-deck weighbridge is designed to work in harsh conditions and is particularly suited to locations on the roads where overloading is a problem. The platform is made from a welded steel superstructure with a durbar surface plate for non-slip and maximum strength.

Plug-And-Weigh™ technology with factory calibrated Weightel™ digital load cells means that set-up time on site is minimal. No special tools are needed to install the weighbridge system. Usually site calibration is carried out to check the platforms, and should be repeated every six months. The sophisticated electronic circuits have been sealed against the elements to ensure a long and trouble free life.

Weights from each platform show on an internal array of LCD displays and, for confirmation to the driver, external displays also show the weights, including the gross vehicle weight.

A key feature of the Ton-Tel Multi-Deck Weighbridge is the fast turn round time to maximise vehicle throughput. Data is input by an operator who can choose from drop down boxes to speed up the selection process and weight capture is within seconds, making a highly efficient system. The weighbridge may also be connected to ANPR cameras to speed up identification of the vehicle.

**Griffith Elder and Company Ltd**  
1 Oaklands Park  
Bury St Edmunds  
Suffolk  
IP33 2RW  
United Kingdom

Telephone: +44 1284 719619  
Fax: +44 1284 700822  
Email: [sales@griffith-elder.com](mailto:sales@griffith-elder.com)  
Internet: [www.griffith-elder.com](http://www.griffith-elder.com)

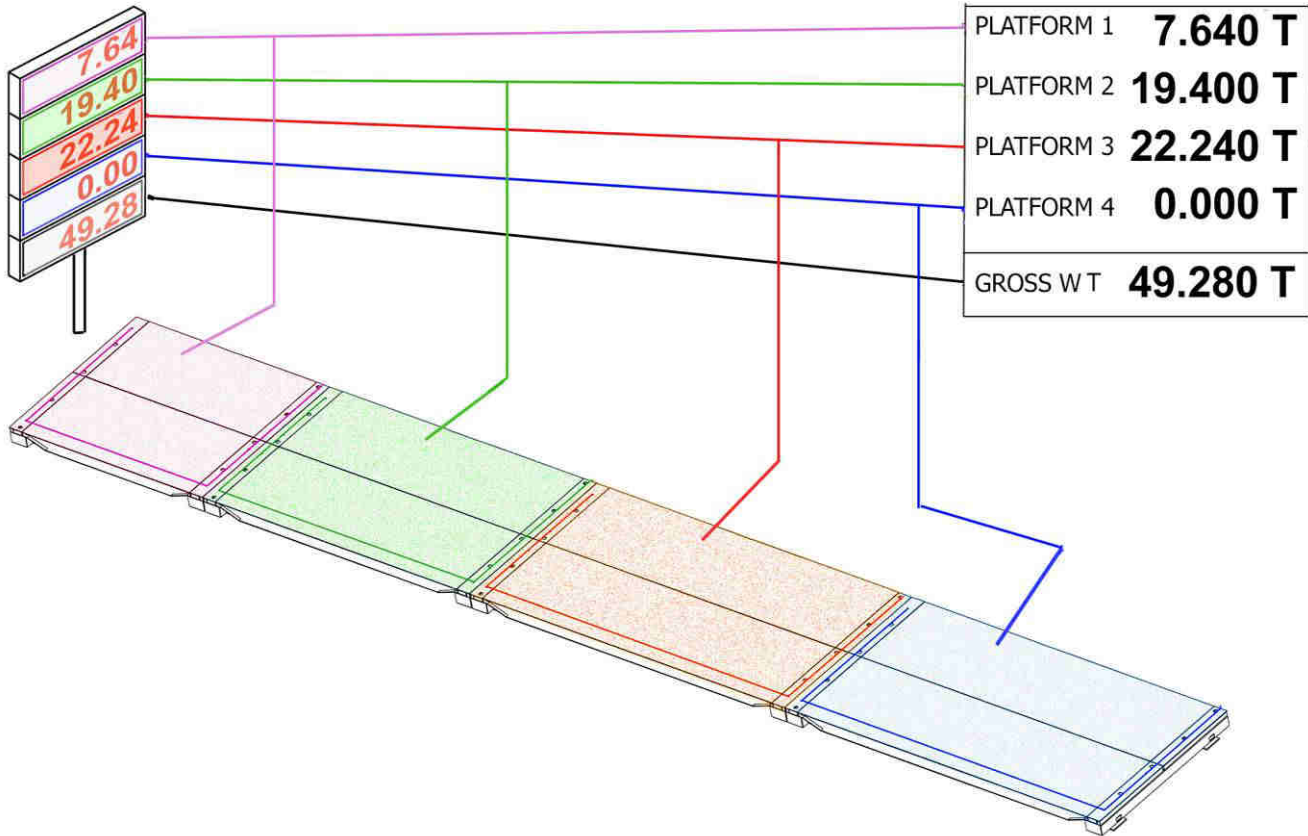

### Operation

Weighing groups of axles is an established method of accurately weighing a vehicle and is the basis of the Ton-Tel Multi-Deck system. Small vehicles are weighed on two platforms, bigger trucks and tractors and trailers are weighed on two, three or four platforms, depending on the configuration of the axles.

As a vehicle drives onto the weighbridge it is controlled by traffic lights which show the driver when to stop. The weight of each group of axles is automatically captured in just three seconds. Then, when the weighing is complete, these individual weights are automatically added together to give the total weight of the vehicle.



### Installation

The factory calibrated weighbridge comes ready to install at a pre-prepared site.

A signal cable runs from each of the platforms to the Hardware Controller which displays the weights on the indicators. These weights are also relayed directly to the computer. The weighbridge may be used with concrete approach and exit, or on the surface with steel ramps.

### Griffith Elder and Company Ltd

1 Oaklands Park  
Bury St Edmunds  
Suffolk  
IP33 2RW  
United Kingdom

Telephone: +44 1284 719619  
Fax: +44 1284 700822  
Email: sales@griffith-elder.com  
Internet: www.griffith-elder.com

### Large Display

The weight of the axles can be shown on large external displays with 120 mm high red LED digits making the information visible to the driver immediately. An external display can also show the gross weight of the vehicle.

The large displays are fully waterproof. The displays show zero when the platform is idle and when overloads are detected, the appropriate display will flash, showing which sets of axles are causing the problem.

## Ton-Tel Multi-Deck Specifications



**Platform Sizes:** 4.3 metres long by 3 metres, 3.5 metres or 4 metres wide  
 5.3 metres long by 3 metres, 3.5 metres or 4 metres wide  
 6.3 metres long by 3 metres, 3.5 metres or 4 metres wide  
 7.3 metres long by 3 metres, 3.5 metres or 4 metres wide  
 7.8 metres long by 3 metres, 3.5 metres or 4 metres wide

Any combination of platforms can be used, common sizes are:

- A) Total 24.2 m 4.3 m, 6.3 m, 7.3 m, 6.3 metres
- B) Total 23.2 m 4.3 m, 5.3 m, 6.3 m, 7.3 metres
- C) Total 25.2 m 6.3 m, 6.3 m, 6.3 m, 6.3 metres
- D) Total 24.7 m 4.3 m, 6.3 m, 7.8 m, 6.3 metres

**Total length of weighbridge** From 21 metres to 30 metres

**Maximum Weight on Platform:** typically 60 tonnes on any one platform using 20 tonne load cells. Can be from 20 tonnes to 100 tonnes depending on load cell choice.

**Maximum Total Vehicle Weight:** Up to 250 tonnes (depending on platform configuration).

**Static accuracy:** Compliance with OIML III. Typically +/- 10 kg up to 10 t, +/- 20 kg up to 40 t, +/- 30 kg above 40 tonnes on each platform.

**Indicator resolution:** 10 kg or 20 kg.

**Power requirements:** 110/220 v ac; 50/60 hz.

**Platform type:** Rigid Load Receptor. Composite welded construction, mild steel with Durbar plate surface, epoxy coated.

**Load cells:** Digital load cells from 6 tonnes to 30 tonnes capacity each, integrated into the rigid load receptor No requirement to fix to foundations. Welded caps, Sealed to IP68. Stainless steel construction.

**Electronics:** Microprocessor weighing control sealed to IP68.

**Operating temperature range:** -20°C to +60°C

**Computer Software:** Ton-Tel Multi-Deck Software, type number 84-0180.

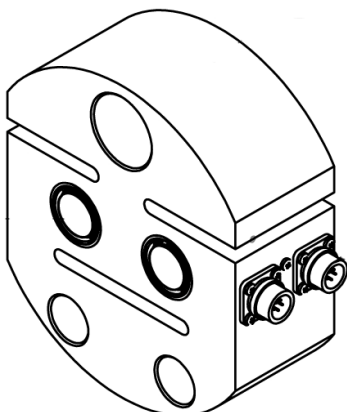



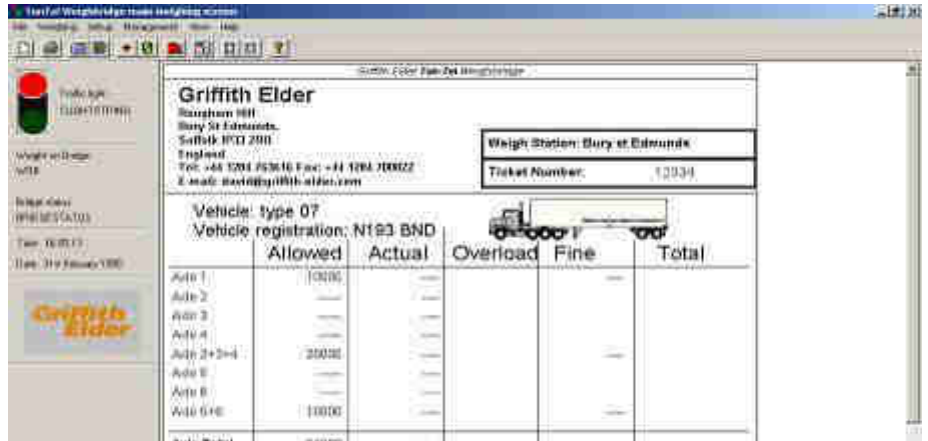

### Multi-Deck Computer Software

The Ton-Tel Multi-deck Computer Software is a powerful yet easy to use system for recording and analysing all vehicles, by groups of axles, to give a ticket showing the all the relevant information needed for monitoring and controlling vehicle weights on the highway. All axle group weights are automatically captured and vehicle classification is chosen from a drop down box which shows a picture for ease of recognition. The program also monitors and records all vehicle movements.

Fines can be levied at different rates on separate classes of vehicle, and be configured according to the laws of the country. The actual weights recorded are compared to those allowed and the fine will show on the ticket.

Additional information concerning each vehicle can be easily entered using the drop down boxes. All Weighing operations are automatically recorded in a secure database.

### Password Protection

The Multi-Deck Weighbridge Software supports multiple user Accounts with configurable secure access rights so that only authorised personnel can use it. The password system allows groups of users to be set up so that each group has separate allowable tasks and personnel within a group can be allowed or denied access to individual program features. The password protection can be administered locally by the appropriate authority.

### Multi-Lingual Program

The Ton-Tel software is a multi-lingual program with English as the standard language with other languages added as required. Tickets can be produced in which ever language has been chosen and reports can show tickets in more than one language.

### Ton-Tel Suite of Software

The Ton-Tel software includes a main program with user interface, a second program that runs in the background for transfer of tickets to a central database, a program for backing up the local database, a program for archiving old weighbridge tickets and a module that can be configured to communicate with other databases.

### Software Team in-house

Griffith Elder have a team of computer programmers who are available to customise the program, including the method by which fines are calculated and any special requirements for vehicle identification. The tickets can be formatted as needed to suit the specification and logo, station address and other parameters can be added to show on the tickets.



### Ton-Tel Software Languages Available

English

Chinese

French

Arabic

Farsi

Russian

**Griffith Elder and Company Ltd**  
1 Oaklands Park  
Bury St Edmunds  
Suffolk  
IP33 2RW  
United Kingdom

Telephone: +44 1284 719619  
Fax: +44 1284 700822  
Email: sales@griffith-elder.com  
Internet: www.griffith-elder.com

## Ton-Tel Multi-Deck Reports

Generate report

And will show weighings..

Numbered

From: [ ] to: [ ]

In time period

date format: dd/mm/yyyy time format: hh:mm:ss

From: 27/06/2002 14:20:00 to: 28/06/2002 14:20:00

The report will have headings for..

Axle Weight  
 Vehicle classification  
 Date / Time  
 Vehicle information  
 Operator information  
 Number of infractions  
 Fine

Concerning vehicle classification: [ ]  
 Concerning vehicle classification: [ ]

Cancel Generate



### Reports

The system contains a powerful reporting facility. The operator selects the parameters for the report from a simple screen by ticking boxes and selecting options. A template is then generated. Several templates can be made to report on different aspects of the data. For instance it may be that a report would include all vehicles from one owner, or all records for a particular vehicle. Many options exist for choosing which data to include. A preview window allows the report to be seen as it will be when printed out.

Reports are created by choosing a template and putting in the dates from and to for which the data is to be included. Hence one template can be used to create the same report over and over again, using different dates.

Information can easily be exported from the Ton-Tel program to other programs for further data analysis. The software is compatible with all spread-sheets, csv format files, or may be printed directly as a pdf document.

For each vehicle that is weighed a separate ticket is produced and stored in the database. Any of the data on the ticket can be searched in order to report on specific items. It is also possible to see the tickets and create reports on another computer on a local area network and finished tickets can be printed out exactly as they were taken.

Reports can be done locally at a weigh station of all the tickets created at that station. Additionally each station can send copies of the tickets to a central database. The central database collates all the results from the individual weighing stations so that reports from the central database can include vehicles that have visited more than one station. For instance it is possible to report on a particular vehicle to see how often it is in contravention of the weight limit rules. Or, a report could be run to detect a particular company that is suspected of continually overloading its trucks.

The reporting system will allow easy extraction of statistics. For example which classification of vehicle has the most infractions.

When data is extracted from the database to put into a report, the information still remains within the database so that many reports can be made from the same information. All and any data can be printed off in the form of a weighbridge ticket, a fine or tariff invoice, or a report. Searching of captured and recorded information in the database is possible on any of the data fields on a ticket.



**Griffith Elder and Company Ltd**  
1 Oaklands Park  
Bury St Edmunds  
Suffolk  
IP33 2RW  
United Kingdom

Telephone: +44 1284 719619  
Fax: +44 1284 700822  
Email: sales@griffith-elder.com  
Internet: www.griffith-elder.com



### Capable of recording/storing all traffic data including:

Weigh Station Identification / Location	Automatic, Pre-entered
Date and time when the vehicle weighed	Automatic
Sequential ticket number	Automatic
Vehicle Classification, including axle format	Manual Pick from list
Number of axles per vehicle	From classification
Load on axle groups (tandems and tri-axles)	Automatic
Gross weight of the vehicle	Automatic
Equivalent Legal Weights	From classification
Adjusted Legal Weights, including percentage tolerance	From classification
Axle group overload	Automatic
Gross Weight overload	Automatic
Percentage overloads	Automatic
Compute fines/charges based on overloads	Automatic, rates pre-entered
Compute tariffs based on classification	Automatic
Limits and fine rates which can be variable	from vehicle classification
Vehicle Licence or Registration Number	Manual entry Or caught from camera
Origin of vehicle	Manual entry from drop down box
Destination of vehicle	Manual entry from drop down box
Product type carried	Manual entry from drop down box
Driver/Vehicle operator	Manual entry type-in
Vehicle Owner/company	Manual entry type-in
Name of scale operator	Automatic (after log-in)
Name of weighbridge controller	Manual entry from drop down box
Download the data and reports to the printer	Manual by operator
Definable fields for more information	Manual Entry

**Griffith Elder and Company Ltd**  
1 Oaklands Park  
Bury St Edmunds  
Suffolk  
IP33 2RW  
United Kingdom

Telephone: +44 1284 719619  
Fax: +44 1284 700822  
Email: sales@griffith-elder.com  
Internet: www.griffith-elder.com